

DASH NO. RANGE	"D" DIA. RANGE	"E" DIMENSION	"R" RADIUS	"T" GAUGE
-4 THRU -16	1/4" TO 1"	"D"/2 + .514	.06	.031
-17 THRU -96	1-1/16" TO 6"	"D"/2 + .534	.11	.050

REV.	CHANGE	DATE	BY	CHK'D	APPR
P	SEE DRAWING CHANGE RECORD ON FILE.	02/18/16	HAD	SMJ	HAD

S344

MATERIAL & FINISH CODES:

METAL: "NO CODE" 1008/1020 LOW CARBON STEEL PER ASTM A 1008, ASTM A 109, QQ-S-698
 FINISH: ZINC PLATE GOLD PER ASTM B 633, Fe/Zn 8, TY. II
 "P" 1008/1020 LOW CARBON STEEL PER ASTM A 1008, ASTM A 109, QQ-S-698
 FINISH: ZINC PLATE GOLD PLUS SEALER PER ASTM B 633, Fe/Zn 13, TY. II
 "D" 2024-T42 ALUMINUM ALLOY PER AMS-QQ-A-250/5
 FINISH: NONE
 "SS" 304/321 STAINLESS STEEL PER AMS 5513/AMS 5510
 FINISH: NONE

CUSHION: "G" GENERAL PURPOSE EPDM PER SAE J200 M3 BA 710 C12
 COLOR: BLACK
 "H" GENERAL PURPOSE SILICONE PER AMS 3303 WITH 100 LB/IN. MIN. TEAR
 COLOR: RED/ORANGE
 "N" GENERAL PURPOSE NEOPRENE PER AMS 3209
 COLOR: BLACK
 "T" TEFLON SKIVED PER AMS 3652
 COLOR: WHITE
 "B" BARE CLAMP

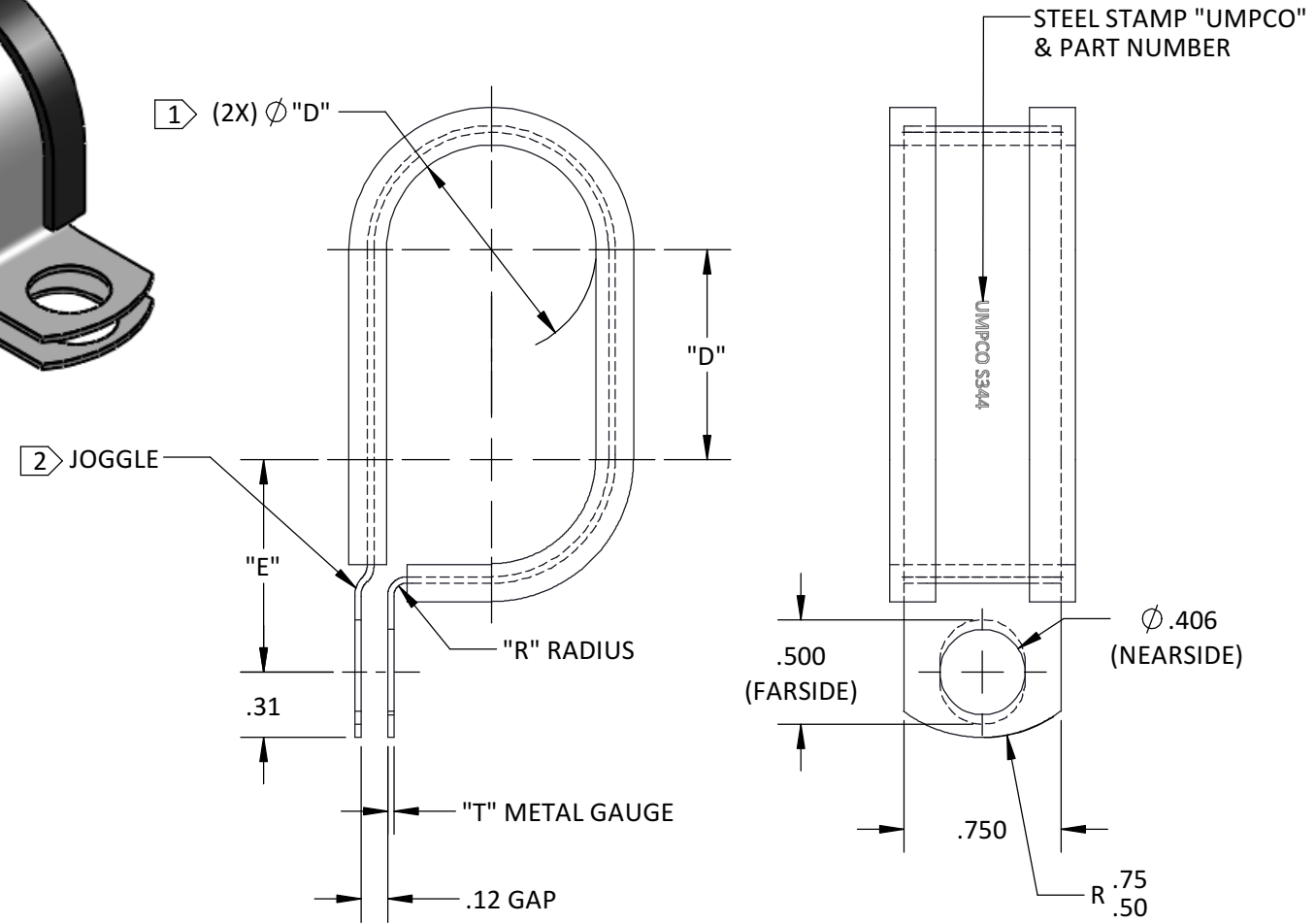
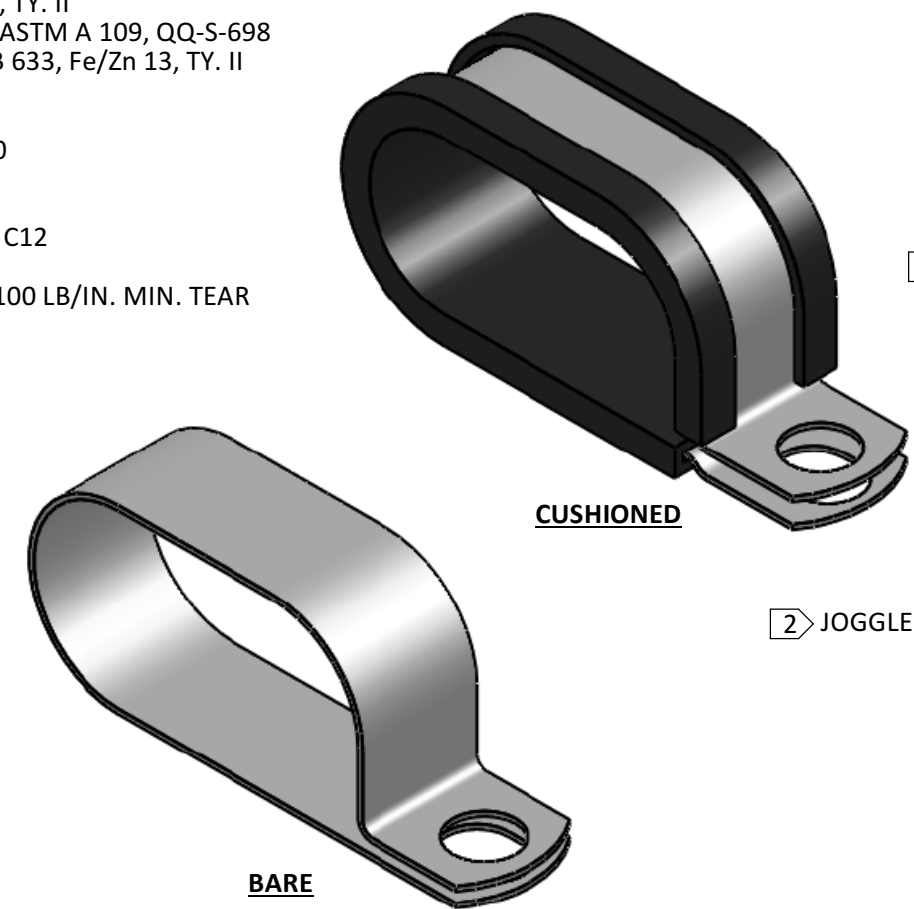

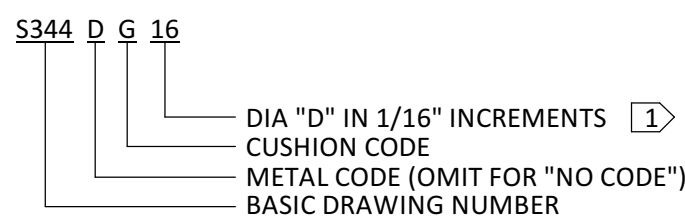

EXAMPLE OF PART CALLOUT:

1" DIA. ALUM. CLAMP W/EPDM CUSHION



- NOTES:**
- 1) DIAMETER "D" REFERS TO METAL SURFACE WHEN BARE CLAMP IS REQUIRED.
 - 2) BARE CLAMPS WILL NOT HAVE A JOGGLE.
 - 3) CLAMPS FURNISHED IN THE NORMAL OPEN (SPRINGBACK) CONDITION.
 - 4) INSPECT PER MIL-C-8603 CLOSURE TEST.

REFERENCES: -	-	-	-
LIMITS ON DIMENSIONS UNLESS OTHERWISE SPECIFIED:	ANGULAR: X ± 5°	 UMPCO . INC. 7100 LAMPSON AVE. P.O. BOX 5158 GARDEN GROVE, CA. 92846	FSCM/CAGE CODE No. 18076
	DECIMAL: .XX ± .03 .XXX ± .015		RJE KEL LJS
GENERAL MACHINE FINISHES EXCEPT AS NOTED:  INTERPRET GEOMETRIC TOLERANCING PER: ASME-Y14.5M	<small>PROPRIETARY AND CONFIDENTIAL</small> <small>THE INFORMATION CONTAINED IN THIS DRAWING IS THE SOLE PROPERTY OF UMPCO, INC. ANY REPRODUCTION IN PART OR AS A WHOLE WITHOUT THE WRITTEN PERMISSION OF UMPCO, INC IS PROHIBITED.</small>		11/06/76 11/06/76 04/22/99
REMOVE ALL BURRS AND BREAK SHARP EDGES .010 MAX	ACT. WGHT. - CALC. WGHT. -	CLAMP, LOOP-CUSHIONED, MULTI-TUBE, EQUAL DIAMETER FOR 3/8" MOUNTING SCREW PART AND/OR ASSEMBLY DESCRIPTION	SIZE B S344 PRINT NUMBER