

EATON CORPORATION - CONFIDENTIAL AND PROPRIETARY
 NOTICE TO PERSONS RECEIVING THIS DOCUMENT AND/OR TECHNICAL INFORMATION
 THIS DOCUMENT, INCLUDING THE DRAWING AND INFORMATION CONTAINED THEREON, IS CONFIDENTIAL AND IS THE EXCLUSIVE PROPERTY OF EATON CORPORATION, AND IS MERELY ON LOAN AND SUBJECT TO RECALL BY EATON AT ANY TIME, BY TAKING POSSESSION OF THIS DOCUMENT. THE RECIPIENT ACKNOWLEDGES AND AGREES THAT THIS DOCUMENT CANNOT BE USED IN ANY MANNER ADVERSE TO THE INTERESTS OF EATON AND THAT NO PORTION OF THIS DOCUMENT MAY BE COPIED OR OTHERWISE REPRODUCED WITHOUT THE PRIOR WRITTEN CONSENT OF EATON. IN THE CASE OF CONFLICTING CONTRACTUAL PROVISIONS, THIS NOTICE SHALL GOVERN THE STATUS OF THIS DOCUMENT.
 ©2016 Eaton Corporation, All Rights Reserved.

REVISIONS				
REV.	DESCRIPTION	ECO NO	DATE	ECO BY
A	INITIAL RELEASE	106950	2016/08/11	A.L

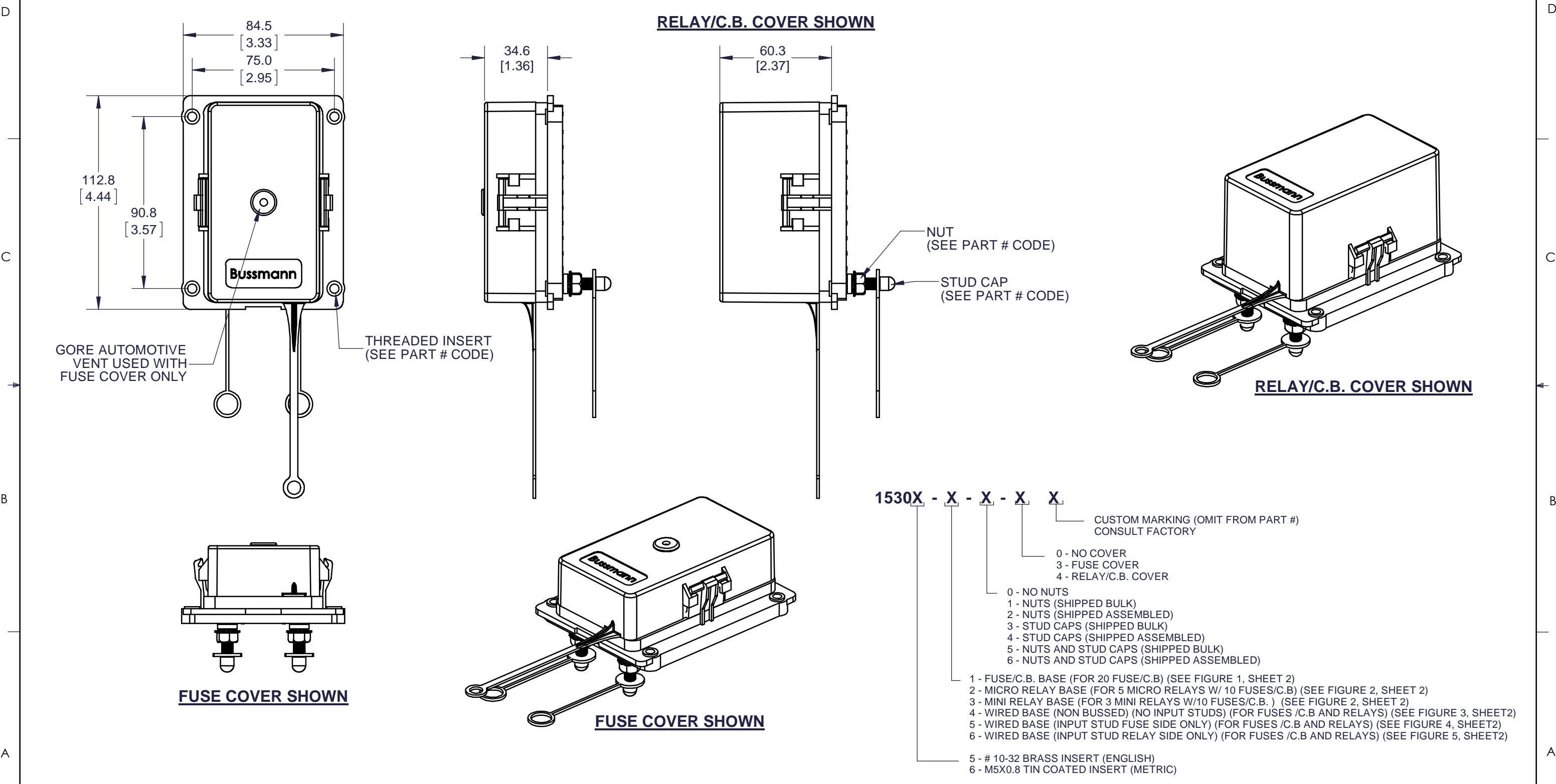

UNLESS OTHERWISE SPECIFIED DIMENSIONS IN INCHES (MILLIMETERS)	
X.X ±0.1	X ±3
X.XX ±0.02	X.X ±0.5
X.XXX ±0.005	X.XX ±0.13
X° ±1	
X.X° ±0.5	

○ CAPSULE AROUND DIMENSION INDICATES INCOMING INSPECTION REQUIRED
 △ INDICATES CRITICAL CHARACTERISTIC (MUST MEET CPK REQUIREMENTS)

DRAWING IN ACCORDANCE WITH
 ASME Y14.100 - 2013
 ASME Y14.1M - 2012
 STANDARDS COMPLIANCE

MATERIAL: N/A
 FINISH: N/A
 RELATED DOCUMENT: HIGH LVL ASSY

DRAFTER/DESIGNER Albert Luu	DATE (YYYY/MM/DD) 2016/08/11
ENGINEERING APPROVED	MANUFACTURING
CHANGE RESPONSIBILITY Tualatin	ECO No 106950

TITLE RTMR SALES DRAWING				
SIZE B	DRAWING NUMBER 1530X-X-X-X-SALES	REVISION A		
THIRD ANGLE PROJECTION	PLANT CODE	CLASS CODE 3	SCALE 1:2	SHEET 1 OF 3

EATON CORPORATION - CONFIDENTIAL AND PROPRIETARY
 NOTICE TO PERSONS RECEIVING THIS DOCUMENT AND/OR TECHNICAL INFORMATION

THIS DOCUMENT, INCLUDING THE DRAWING AND INFORMATION CONTAINED THEREON, IS CONFIDENTIAL AND IS THE EXCLUSIVE PROPERTY OF EATON CORPORATION, AND IS MERELY ON LOAN AND SUBJECT TO RECALL BY EATON AT ANY TIME, BY TAKING POSSESSION OF THIS DOCUMENT. THE RECIPIENT ACKNOWLEDGES AND AGREES THAT THIS DOCUMENT CANNOT BE USED IN ANY MANNER ADVERSE TO THE INTERESTS OF EATON AND THAT NO PORTION OF THIS DOCUMENT MAY BE COPIED OR OTHERWISE REPRODUCED WITHOUT THE PRIOR WRITTEN CONSENT OF EATON. IN THE CASE OF CONFLICTING CONTRACTUAL PROVISIONS, THIS NOTICE SHALL GOVERN THE STATUS OF THIS DOCUMENT.

©2016 Eaton Corporation, All Rights Reserved.

REVISIONS				
REV.	DESCRIPTION	ECO NO	DATE	ECO BY
-	See Sheet1	-	-	-

**FOR TERMINAL REMOVAL USING
 DELPHI TOOL PART # 12094430**

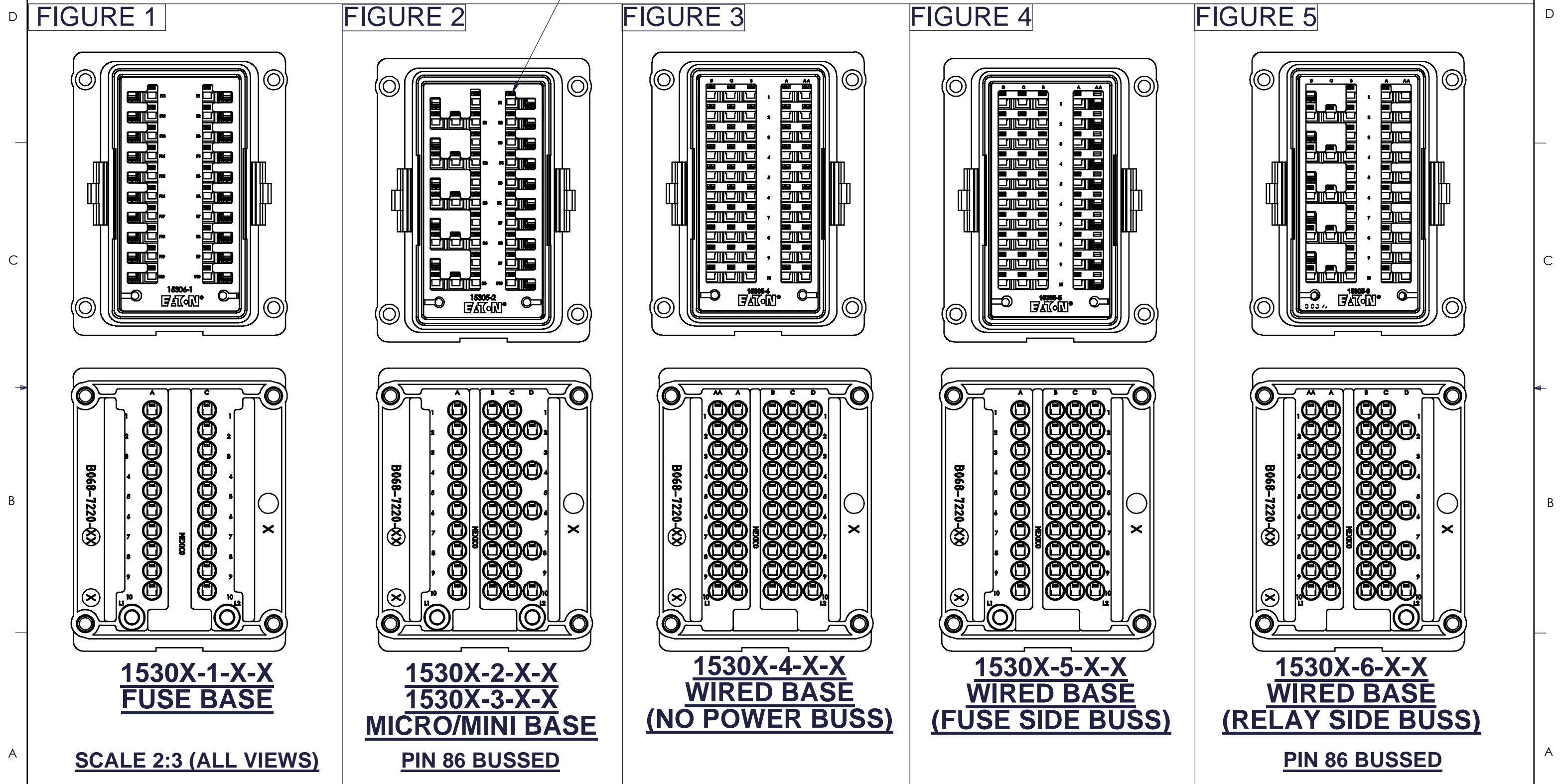

UNLESS OTHERWISE SPECIFIED DIMENSIONS IN

INCHES		MILLIMETERS	
X.X	±0.1	X	±3
X.XX	±0.02	X.X	±0.5
X.XXX	±0.005	X.XX	±0.13
X°	±1		
X.X°	±0.5		

○ CAPSULE AROUND DIMENSION INDICATES INCOMING INSPECTION REQUIRED

△ INDICATES CRITICAL CHARACTERISTIC (MUST MEET CPK REQUIREMENTS)

DRAWING IN ACCORDANCE WITH
 ASME Y14.100 - 2013
 ASME Y14.1M - 2012
 STANDARDS COMPLIANCE

MATERIAL: N/A
FINISH: N/A
RELATED DOCUMENT: HIGH LVL ASSY

DRAFTER/DESIGNER Albert Luu		DATE (YYYY/MM/DD) 2016/08/11	
ENGINEERING APPROVED		MANUFACTURING	
CHANGE RESPONSIBILITY Tualatin		ECO No 106950	

TITLE RTMR SALES DRAWING				
SIZE B	DRAWING NUMBER 1530X-X-X-X-SALES	REVISION A		SHEET 2 OF 3
THIRD ANGLE PROJECTION	PLANT CODE	CLASS CODE 3	SCALE 1:2	

EATON CORPORATION - CONFIDENTIAL AND PROPRIETARY
 NOTICE TO PERSONS RECEIVING THIS DOCUMENT AND/OR TECHNICAL INFORMATION

THIS DOCUMENT, INCLUDING THE DRAWING AND INFORMATION CONTAINED THEREON, IS CONFIDENTIAL AND IS THE EXCLUSIVE PROPERTY OF EATON CORPORATION, AND IS MERELY ON LOAN AND SUBJECT TO RECALL BY EATON AT ANY TIME, BY TAKING POSSESSION OF THIS DOCUMENT. THE RECIPIENT ACKNOWLEDGES AND AGREES THAT THIS DOCUMENT CANNOT BE USED IN ANY MANNER ADVERSE TO THE INTERESTS OF EATON AND THAT NO PORTION OF THIS DOCUMENT MAY BE COPIED OR OTHERWISE REPRODUCED WITHOUT THE PRIOR WRITTEN CONSENT OF EATON. IN THE CASE OF CONFLICTING CONTRACTUAL PROVISIONS, THIS NOTICE SHALL GOVERN THE STATUS OF THIS DOCUMENT.
 ©2016 Eaton Corporation, All Rights Reserved.

REVISIONS				
REV.	DESCRIPTION	ECO NO	DATE	ECO BY
-	See Sheet1	-	-	-

THE TABLES BELOW ARE FOR REFERENCE ONLY, AND IS SUBJECT TO CHANGES BY DELPHI PACKARD.

DELPHI METRI-PACK 280 TANGLESS TERMINALS SEALED		
DELPHI PART #	CABLE RANGE (mm sq)	WIRE SIZE
12110846	0.35 - 0.50	22 - 20
12110847	0.80 - 1.0	18 - 16
12129409	1.0 - 2.0	16 - 14
12110845	2.0 - 3.0	14 - 12
12110853	3.0 - 5.0	12 - 10

DELPHI METRI-PACK 280 CABLE SEALS		
DELPHI PART #	CABLE DIAMETER	COLOR
12034365	1.29 - 1.70	DARK RED
12089679	1.60 - 2.15	PURPLE
12041351	2.03 - 2.42	TAN
12015323	2.03 - 2.85	GREEN
12010293	2.81 - 3.49	LIGHT GRAY
12015193	3.45 - 4.30	BLUE

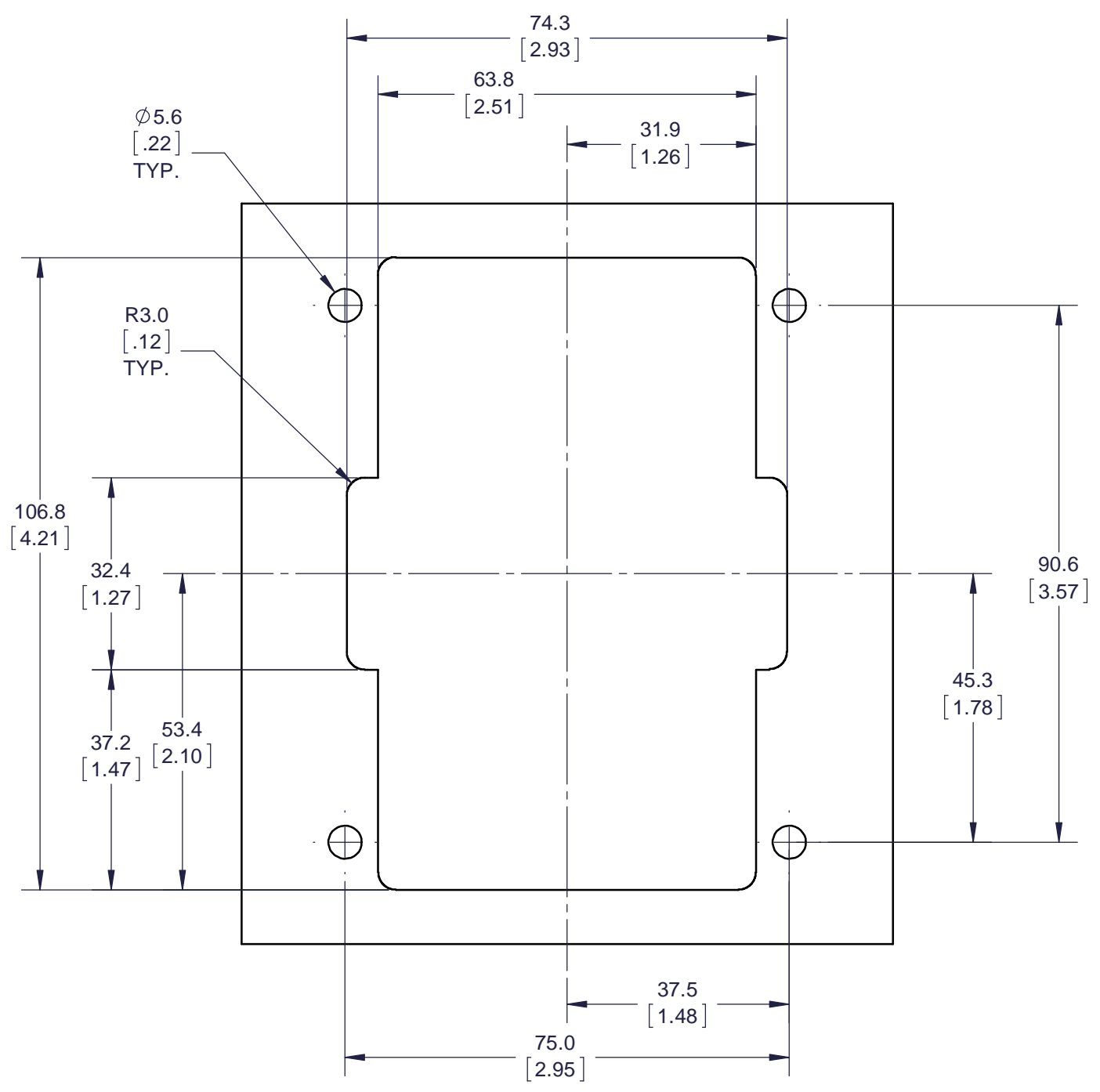

RECOMMENDED PANEL CUTOUT SIZE
SCALE 1:1

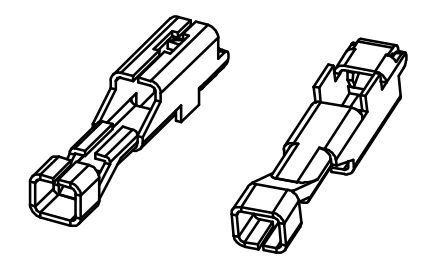

SCALE 2:1

DELPHI TERMINAL REMOVAL TOOL	
DELPHI PART #	12094430



DELPHI TERMINALS, CABLE SEALS, CAVITY PLUGS AND TERMINAL REMOVAL TOOL SHOWN ARE NOT PROVIDED BY EATON.

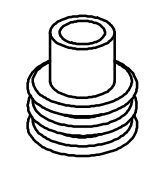

SCALE 2:1

DELPHI METRI-PACK CAVITY PLUG	
DELPHI PART #	COLOR
12010300	GREEN

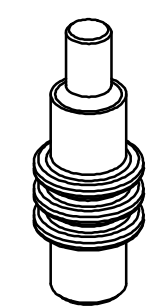

SCALE 2:1

- NOTES:**
- MOUNTING TORQUE:
 THREADED INSERTS (#10-32 UNF) OR (M5X0.8): 18±2 IN-LBS (22 IN-LBS MAX).
 INPUT STUDS (M6X1): 40±5 IN-LBS (50 IN-LBS MAX).
 - HOUSING: 94V0 THERMOPLASTIC.
 - INTERNAL BUS BAR: TIN PLATED COPPER.
 - DIMENSIONS PROVIDED ARE FOR REFERENCE ONLY.
 - IP RATING: IP66, VALID WHEN COVER, SEALED TERMINALS AND PLUGS ARE PROPERLY INSTALLED.
 - TERMINAL REMOVAL TOOL: DELPHI PART # 12094430



UNLESS OTHERWISE SPECIFIED DIMENSIONS IN	
INCHES	(MILLIMETERS)
X.X ±0.1	X ±3
X.XX ±0.02	X.X ±0.5
X.XXX ±0.005	X.XX ±0.13
X° ±1	
X.X° ±0.5	

○ CAPSULE AROUND DIMENSION INDICATES INCOMING INSPECTION REQUIRED
 △ INDICATES CRITICAL CHARACTERISTIC (MUST MEET CPK REQUIREMENTS)

DRAWING IN ACCORDANCE WITH
 ASME Y14.100 - 2013
 ASME Y14.1M - 2012
 STANDARDS COMPLIANCE

MATERIAL: N/A
 FINISH: N/A
 RELATED DOCUMENT: HIGH LVL ASSY

DRAFTER/DESIGNER		DATE (YYYY/MM/DD)	
Albert Luu		2016/08/11	
ENGINEERING APPROVED		MANUFACTURING	
Tualatin		106950	

RTMR SALES DRAWING				
SIZE	DRAWING NUMBER	REVISION	CLASS CODE	SCALE
B	1530X-X-X-X-SALES	A	3	1:2
THIRD ANGLE PROJECTION				
				SHEET 3 OF 3