

Power & Ground Bus Splitter

This Power & Ground bus splitter provides a cost effective and space efficient way of connecting multiple devices to the Power & Ground bus. This module reduces cost by eliminating Y adapters and extra harnesses typically used to provide additional connections to the bus.

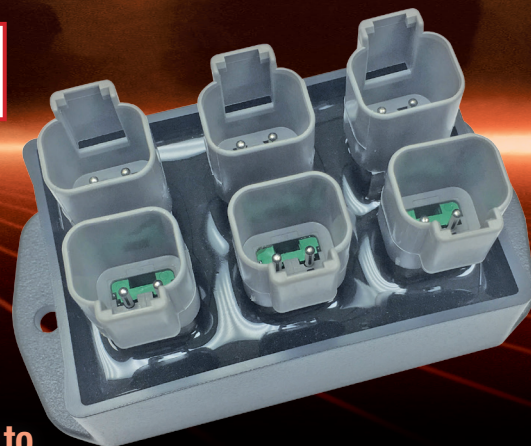

99-0290

PRODUCT FEATURES

- Reduces bus harnessing
- Reduces actual and production costs
- Reduces bus connections increasing quality & durability
- Eases troubleshooting of harnesses
- Potted for a true IP67 rating
- Operating & storage temp rating
-45°C to +85°C
- 6 x DT04-2P Deutsch Connectors
12 x 2 pin DT (Tin plated pins)
6 x W2P Green Wedge Locks
- Used for Power & Ground Distribution

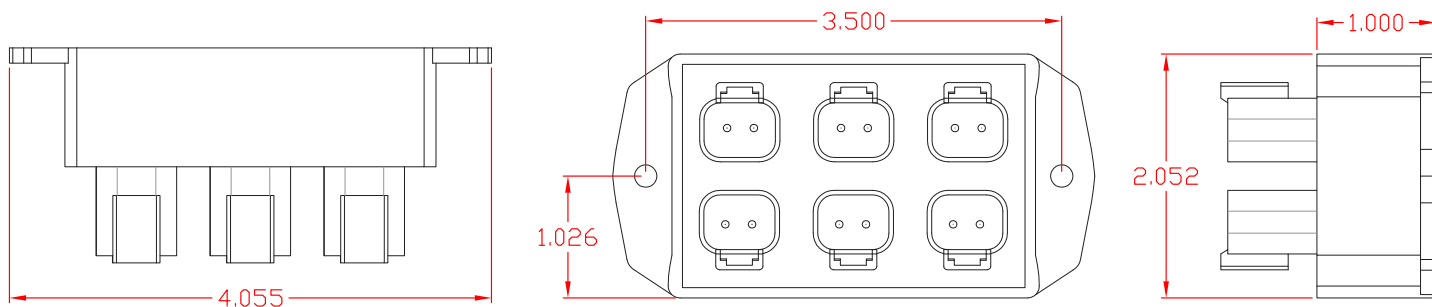
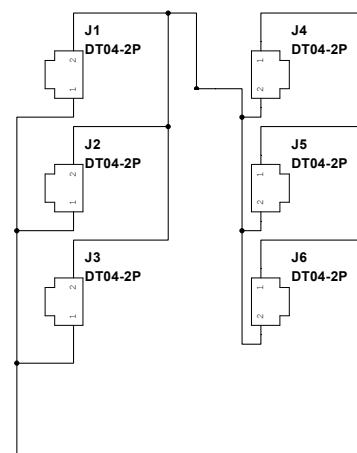
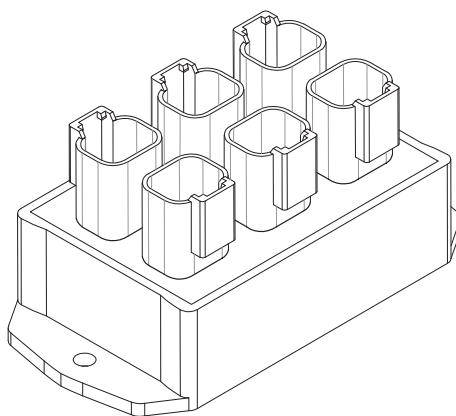

TROMBETTA
DC Power Solutions for a Harsh World