

MATERIAL & FINISH CODES:

METAL:	"NO CODE"	1008/1020 LOW CARBON STEEL PER ASTM A 1008, ASTM A 109, QQ-S-698 FINISH: ZINC PLATE GOLD PER ASTM B 633 FE/ZN 8, TY II
	"P"	1008/1020 LOW CARBON STEEL PER ASTM A 1008, ASTM A 109, QQ-S-698 FINISH: ZINC PLATE GOLD PLUS SEALER PER ASTM B 633 FE/ZN 8, TY II
	"D"	2024-T42 ALUMINUM CLAD PER AMS-QQ-A-250/5 FINISH: NONE
	"SS"	304/321 STAINLESS STEEL PER AMS 5513/AMS 5510 FINISH: NONE
CUSHION:	"G"	GENERAL PURPOSE EPDM PER SAE J200 M3BA710, C12 COLOR: BLACK
	"H"	GENERAL PURPOSE SILICONE PER AMS 3303 WITH 100 PSI MIN. TEAR COLOR: RED/ORANGE
	"N"	GENERAL PURPOSE NEOPRENE PER AMS 3209 COLOR: BLACK
	"T"	TEFLON PER AMS 3656 [3]
	"HD"	GENERAL PURPOSE SILICONE PER AMS 3303 WITH 100 PPI MIN. TEAR. COLOR: RED/ORANGE
	"JS"	FLUROSILICONE PER AMS-R-25988, TY. II, CL 2, GRADE 50 COLOR: SOLID BLUE

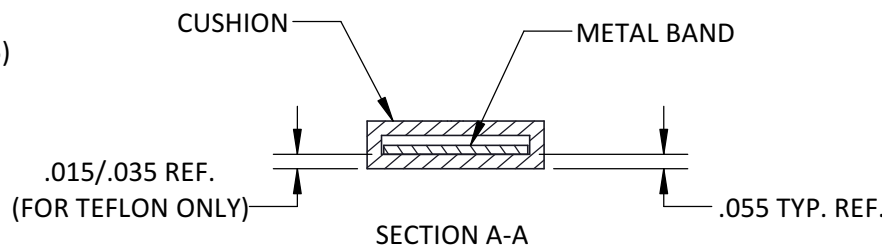

S732

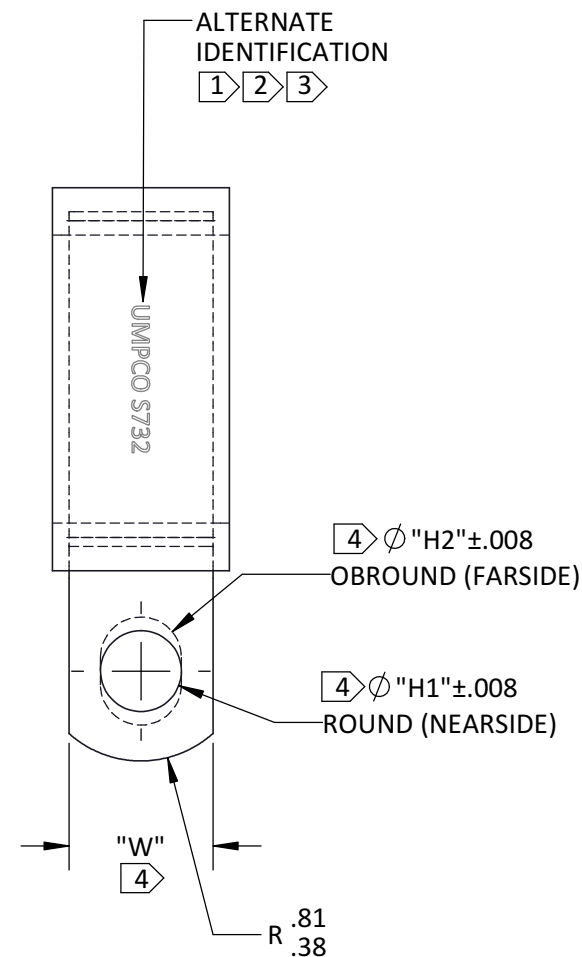
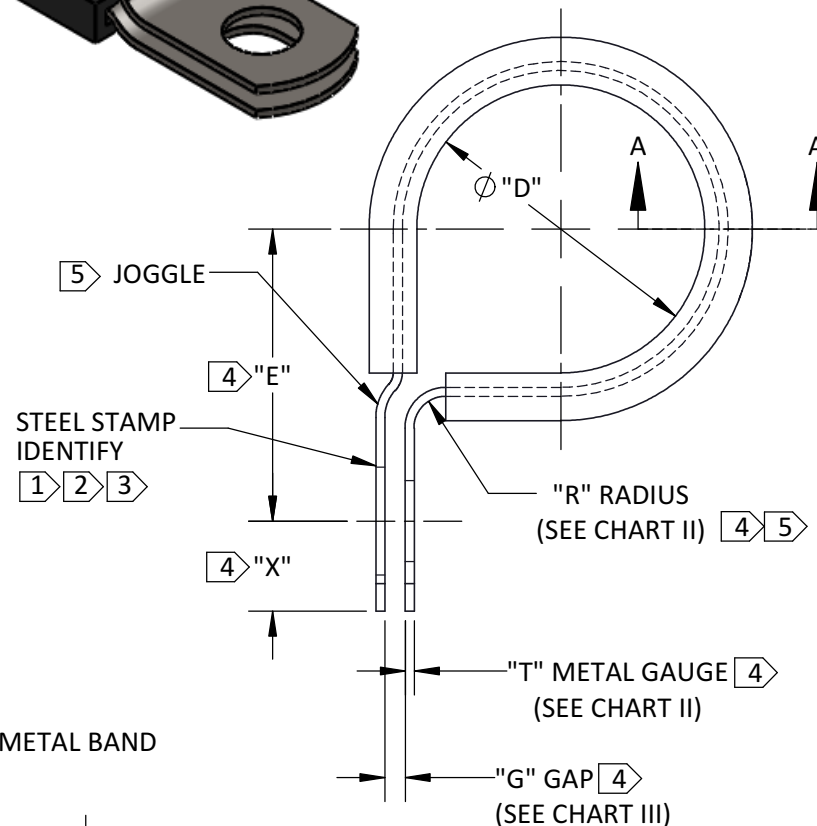

EXAMPLE OF PART CALLOUT:

.281 HOLE, .030 THK., .625 WIDE, 1" DIA., REINFORCED ALUM. BAND W/ EPDM

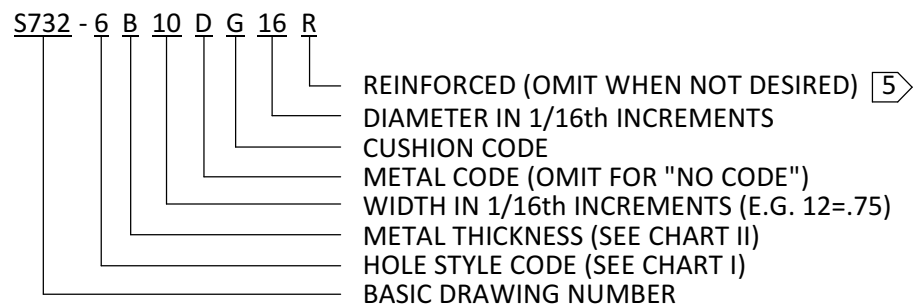

NOTES:

- [1] IDENTIFICATION NOT TO ENCR OACH ON HOLES. [2][3]
- [2] IF IDENTIFICATION IS NOT POSSIBLE DUE TO SIZE LIMITATIONS, ONLY "UMPCO" AND DASH NUMBER TO APPEAR OR DASH NUMBER ONLY.
- [3] ALTERNATE IDENTIFICATION METHODS:
-CLAMPS USING TEFLON CUSHION WILL SHOW STEEL STAMP VISIBLE THROUGH MAT'L.
-RUBBER (INK) STAMP IDENTIFY.
-BULK PACKAGE IDENTIFY WITH "UMPCO" & PART NUMBER AS ACCEPTABLE ALTERNATE METHOD. ADDITIONAL INFO. MAY BE REQ'D, REFER TO CUSTOMER'S REQUIREMENTS.
- [4] SEE SHEET 2 OF 2 FOR CLAMP DIMENSIONS.
- [5] REINFORCED CORNERS & BEADED JOGGLE PER DS1010 WHEN SPECIFIED.
- 6) CLAMPS FURNISHED IN THE NORMAL OPEN (SPRINGBACK) CONDITION.
- 7) INSPECT PER MIL-C-8603 CLOSURE TEST.

REFERENCES: -		-		-		FSCM/CAGE CODE No. 18076			
LIMITS ON DIMENSIONS UNLESS OTHERWISE SPECIFIED:	ANGULAR:	X	± 5°	UMPCO . INC. 7100 LAMPSON AVE. P.O. BOX 5158 GARDEN GROVE, CA. 92846			SMJ	LJS	JLC
	DECIMAL:	.XX	± .03				04/29/96	06/23/96	05/23/96
GENERAL MACHINE FINISHES EXCEPT AS NOTED: INTERPRET GEOMETRIC TOLERANCING PER: ASME-Y14.5M	PROPRIETARY AND CONFIDENTIAL THE INFORMATION CONTAINED IN THIS DRAWING IS THE SOLE PROPERTY OF UMPCO, INC. ANY REPRODUCTION IN PART OR AS A WHOLE WITHOUT THE WRITTEN PERMISSION OF UMPCO, INC IS PROHIBITED.			CLAMP, LOOP-CUSHIONED, "FULL BOX" STYLE			SCALE: NONE	S732	
	REMOVE ALL BURRS AND BREAK SHARP EDGES .010 MAX	ACT. WGHT.	-		PART AND/OR ASSEMBLY DESCRIPTION			PRINT NUMBER	
	CALC. WGHT.	-							



CHART I												
HOLE STYLE CODES & DIMENSIONS												
CODE	HOLE STYLE 1	HOLE STYLE 2	HOLE STYLE 3	HOLE STYLE 4	HOLE STYLE 5	HOLE STYLE 6	HOLE STYLE 7	HOLE STYLE 8	HOLE STYLE 9	HOLE STYLE 10	HOLE STYLE 11	HOLE STYLE 12
"H 1"	.173 THRU	.204 THRU	.204 THRU	.218 THRU	.265 THRU	.281	.281	.344	.406	.438	.468	.531
"H 2"	-	-	-	-	-	.375	.375	.438	.500	.531	.562	.625
"W"	6	6	8	8	8	8, 10,12	8, 10, 12	8, 10, 12	10,12,16	10, 12	12, 16	12, 16
"X"	.188	.188	.218	.218	.218	.312	.375	.312	.312	.440	.440	.440
∅ "D" DASH NO.	"E" ±.015	"E" ±.015	"E" ±.015	"E" ±.015	"E" ±.015	"E" ±.015	"E" ±.015	"E" ±.015	"E" ±.015	"E" ±.015	"E" ±.015	"E" ±.015
-2	"D"/2 + .312	"D"/2 + .395	"D"/2 + .395	"D"/2 + .395	"D"/2 + .395	"D"/2 + .514	"D"/2 + .514	"D"/2 + .514	"D"/2 + .514	"D"/2 + .562	"D"/2 + .562	"D"/2 + .623
-3 TO -8		"D"/2 + .405	"D"/2 + .405	"D"/2 + .405	"D"/2 + .405							
-9 TO -12		"D"/2 + .468	"D"/2 + .468	"D"/2 + .468	"D"/2 + .468							
-13 TO -16		"D"/2 + .452	"D"/2 + .452	"D"/2 + .452	"D"/2 + .452							
-17		-	-	-	-							
-18 TO -30	-	-	"D"/2 + .468	"D"/2 + .468	"D"/2 + .468	"D"/2 + .534	"D"/2 + .534	"D"/2 + .534	"D"/2 + .534	"D"/2 + .582	"D"/2 + .582	"D"/2 + .643
-31 TO -80	-	-	"D"/2 + .475	"D"/2 + .475	"D"/2 + .475							

S732

REV.	CHANGE	DATE	BY	CHK'D	APPR
P	SEE DRAWING CHANGE RECORD ON FILE.	4/5/19	SR	KWE	SR

CHART II		
"T" METAL GAUGE AND "R" RADIUS		
CODE	GAUGE	RADIUS
A	.020	.062
B	.030	
C	.040	.109
D	.050	
E	.060	

CHART III			
"G" GAP ±.015			
FOR DASH NUMBER:	HOLE STYLE CODES		
	1 THRU 5	6 THRU 8	9 THRU 12
-2 THRU -16	.070	.070	.125
-17 THRU -80	.109	.125	

REFERENCES: -	-	-	-
LIMITS ON DIMENSIONS UNLESS OTHERWISE SPECIFIED:	ANGULAR: X ± 5°	 UMPCO . INC. 7100 LAMPSON AVE. P.O. BOX 5158 GARDEN GROVE, CA. 92846	FSCM/CAGE CODE No. 18076
	DECIMAL: .XX ± .03		SMJ LJS JLC
DECIMAL: .XXX ± .015			04/29/96 06/23/96 05/23/96
GENERAL MACHINE FINISHES EXCEPT AS NOTED:	PROPRIETARY AND CONFIDENTIAL THE INFORMATION CONTAINED IN THIS DRAWING IS THE SOLE PROPERTY OF UMPCO, INC. ANY REPRODUCTION IN PART OR AS A WHOLE WITHOUT THE WRITTEN PERMISSION OF UMPCO, INC IS PROHIBITED.		DRAWN CHECKED ENGR
 INTERPRET GEOMETRIC TOLERANCING PER: ASME-Y14.5M		SIZE	SCALE: NONE
REMOVE ALL BURRS AND BREAK SHARP EDGES .010 MAX	ACT. WGHT. -	CLAMP, LOOP-CUSHIONED, "FULL BOX" STYLE	B S732
	CALC. WGHT. -		
		PART AND/OR ASSEMBLY DESCRIPTION	PRINT NUMBER

A

A

B

B

C

C

D

D

E

E

1 2 3 4 5 6 7 8

1 2 3 4 5 6 7 8