

Dimensions

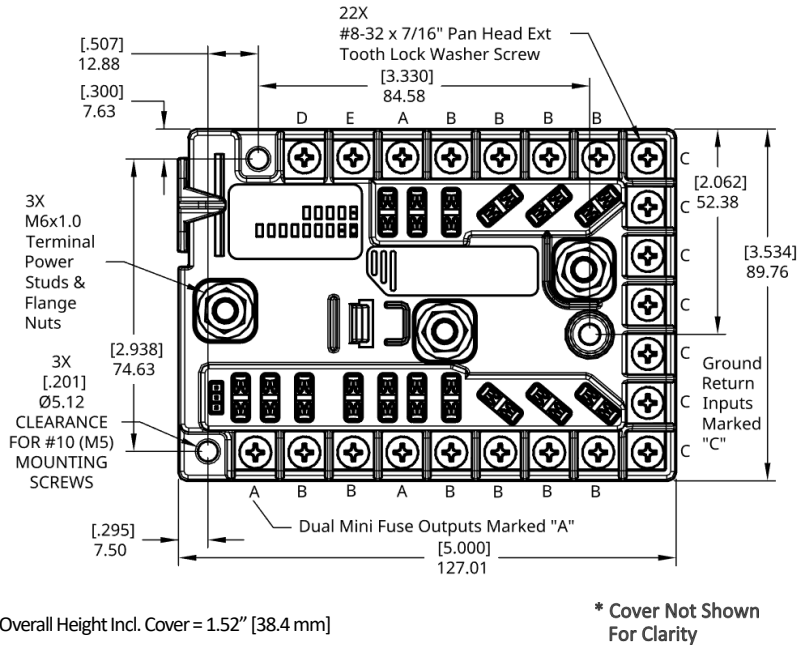

System Diagram

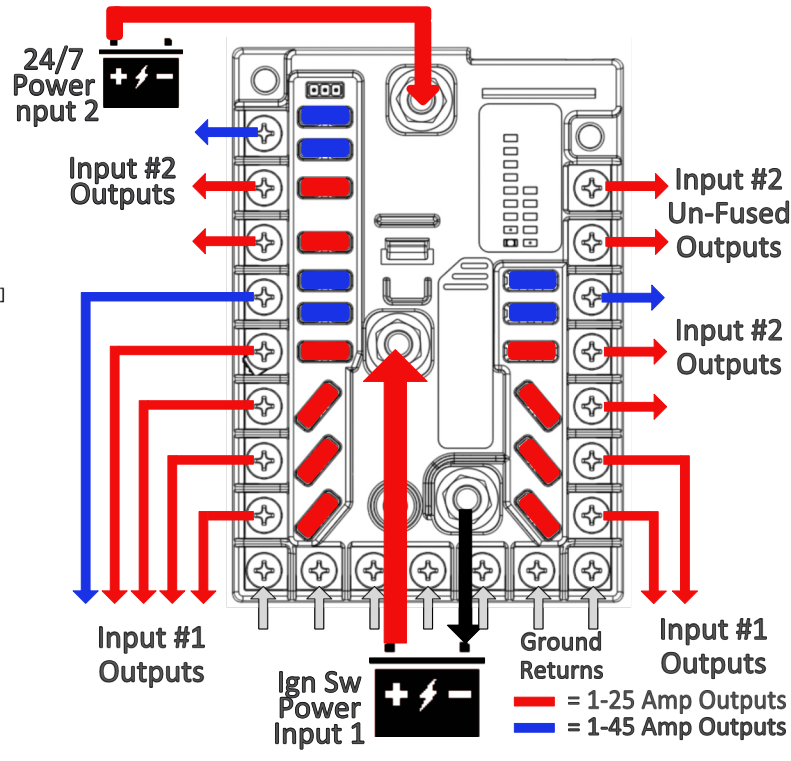

Specifications

| | |
|--|-------------------------------|
| Nominal Voltage (Vdc) | 12/24 Vdc |
| Input Voltage Range (Vdc) | 8.0-36.0 |
| Continuous Current (Total) | 200 A |
| Max Current per Input (#1 & #2) | 100 A |
| Max Output Current (Single / Parallel) | 25 A / 45 A |
| Cable Size to Meet Ratings | 1 AWG (45 mm ²) |
| Maximum Cable Size | 1/0 AWG (55 mm ²) |
| Hardware Material | Stainless Steel Self-Locking |
| Terminal Stud Torque / Max Torque | 60 in-lbs / 80 in-lbs |

*** DISCONNECT BATTERY FROM POWER DISTRIBUTION SYSTEM BEFORE INSTALLING PRODUCT TO PREVENT ELECTRICAL SHOCK OR PRODUCT DAMAGE**

| Part Numbers | Resell Pack | Bulk Pack |
|-----------------------------------|-------------|-----------|
| Split Buss Fuse Block, 13 Circuit | 8033 | 8033B |

* Custom product configurations available, contact us at support@egismobile.com for more information



www.egismobile.com
360.768.1211
Bellingham, WA U.S.A

