

LTR.	REVISIONS	DATE	INT.
⤴	UPDATED DIMENSIONS	11-12-15	RAS

TYP. WALL THICKNESS = 1.5

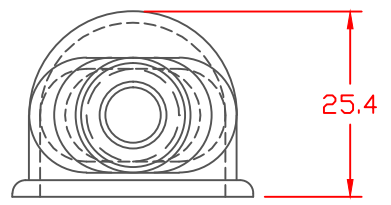
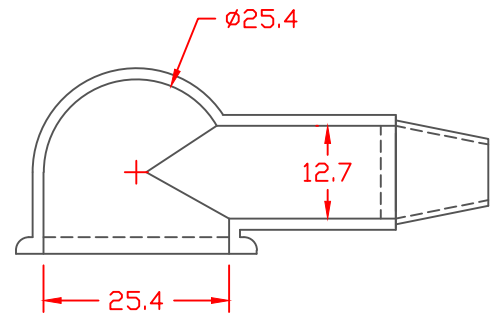

SEAL OPTIONS

SEAL THICKNESS = .8

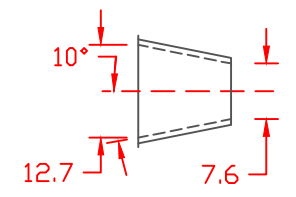

NO. 2  
Cable Gages 8-2

SECTION A-A

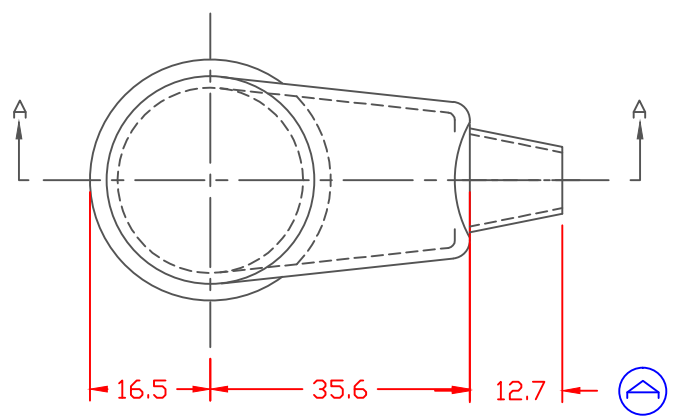

Material:	BLACK PVC
Material Part No	9812-65
Max. Operating Temp:	105 C
Shore Durometer	"A" 10 SEC. 67/63
Specific Gravity:	1.33
Ult. Elongation %:	520
Brittle Temp:	-36 C
Tensile Strength PSI:	1563 PSI
U.L. Rating:	94 V2
MEETS:	FMVSS.302

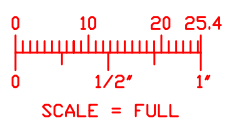

TOLERANCE UNLESS OTHERWISE SPECIFIED: ±.030"/±0.8mm  
RADIAL DIAMETERS TO BE MEASURED OVER MANDRELS,  
RING GAGES OR PIN GAGES OF SUITABLE SIZE

REF:	DATE:	DRN BY:	WEIGHT:
	3-26-98	JC	.019 LBS. / 8.48 G.
TITLE:		CHK'D BY:	
EYELET TERMINAL INSULATOR			
MATERIAL:		PART NO.	
		23545	
COLOR:	DRG CLASS		