

SYMBOL DEFINITION		TOTAL NO OF INSPECTIONS REQUIRED	LIST NO. USED
<input type="checkbox"/>	A DIMENSION WITHOUT AN INSPECTION REPORT SYMBOL DOES NOT REQUIRE INSPECTION. IT MAY BE CONTROLLED ON THE INDIVIDUAL COMPONENT DRAWING.	21	21

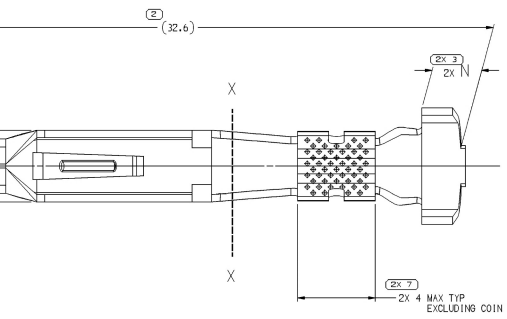

TYPE 101

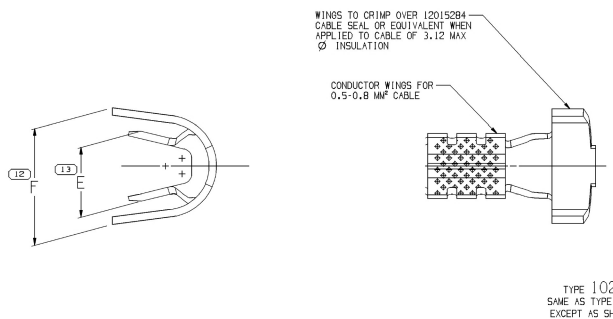

TYPE 102
SAME AS TYPE 101
EXCEPT AS SHOWN

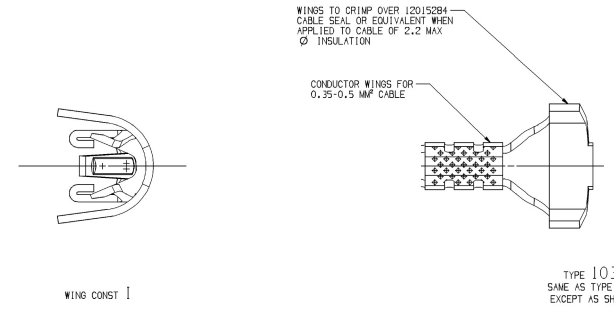

TYPE 103
SAME AS TYPE 101
EXCEPT AS SHOWN

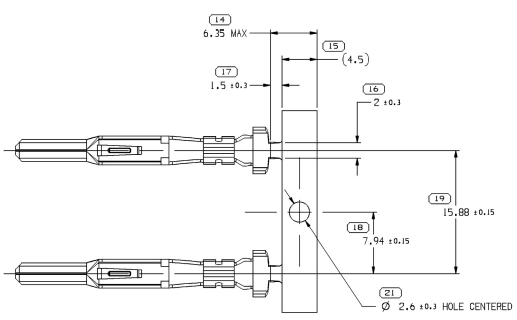
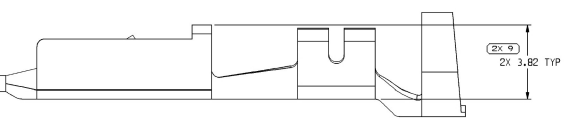

CARRIER STRIP VIEW
SCALE 4:1

- NOTES
- UNLESS OTHERWISE SPECIFIED AND/OR INDICATED: DIMENSIONS ARE TO FACE OF VIEW SHOWN AND AUTOMATICALLY ROUNDED BY COMPUTER FOR INSPECTION. (SEE MATH MODEL FOR PRECISE DIMENSIONS.) FOR ALL OTHER DIMENSIONS NOT SHOWN BUT REQUIRED FOR TOOL BUILD, SEE MATH MODEL FOR PRECISE TOOL PATH DATA.
 - REFERENCE MATING TERMINAL OR EQUIVALENT: 12077411 & 12015054

PART NO	REV	N/P	MAT'L SPEC	MAT'L SIZE	SIZE MMF	ID	DIA	TYPE	WING CONST	F	F	N _{to 19}
35093281	Q2	-	COPPER ALLOY W/ SILVER PLATING	0.381 X 42.04	3-5	11	3-4.2	101	1	4.6	6	2
12129497	A3	-	TIN PLATED COPPER ALLOY	0.381 X 42.04	2-3	13	2.45-3.8	101	1	4	6.4	2
12124977	A9	-	TIN PLATED COPPER ALLOY	0.381 X 42.04	0.35-0.5	21	1.3-2.2	103	11	2.4 ±0.2	6.4	2
12048254	D3	-	TIN PLATED COPPER ALLOY	0.381 X 42.04	3	12	3.49-3.65	101	1	4.6	6	2
12048159	B16	-	TIN PLATED COPPER ALLOY	0.381 X 42.04	0.5-1	19	2.03-3.12	102	1	3.2	5.9	2
12049559	E	-	COPPER ALLOY	0.381 X 42.47	1-2	15	3.13-3.97	101	1	3.6	6	2

DRAWING NUMBER
12089387

SIZE: A1x3
SCALE: 10:1
FRAME NO: 2 OF 2
SHEET NO: 1 OF 1
REV: 10
TYP: -