

# DBT-LD Data Bus Throttle

## Light-Duty Vehicle Throttle

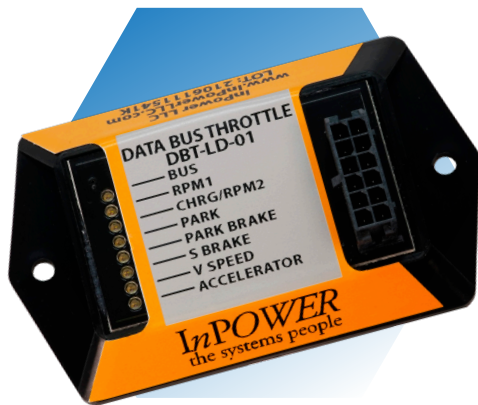

### Technical Description

InPower's DBT-LD Data Bus Throttle provides high idle engine RPM control for light-duty vehicles. It features a plug-and-play design for fast and easy installation. The control module connects to the vehicle's OBD-II diagnostic connector via a cable that includes a second OBD-II connector for any other necessary OBD-II access. It also has an alternate Female connector that can be used based on your application (use one and secure the other). The cable also includes blunt-cut wires for the operating mode inputs, the PTO output signal, and the speed adjustment.

Four light duty throttle models are available to meet your needs, each with one default mode and one override mode. *Note:* Module will not activate unless all chassis ready conditions are satisfied.

DBT-LD-01 has one adjustable preset RPM1 as its override, activated by ground, and *Green Charge* automatic charge protect as its default.

DBT-LD-02 has two adjustable presets RPM1 and RPM2. RPM1 is the override, activated by +12 volts.

DBT-LD-03 has one adjustable preset RPM1 as its override, activated by +12 volts, and *Green Charge* automatic charge protect as its default.

DBT-LD-04 has one adjustable preset RPM1 override, activated by ground, and an On/Off charge protect as its default.

InPower's *Green Charge* activates when the chassis battery enters a low voltage condition. It gradually raises the engine RPM to the minimum necessary to charge the battery before dropping the RPM back to the minimum idle to maximize fuel economy and minimize emissions. The On/Off charge protect immediately boosts the engine RPM to 1500 RPM for faster battery charging.

InPower has designed the DBT's software to support many chassis and model year variations, and more will be added to the library as they are tested. To support our customers in selecting a throttle that is compatible with their specific chassis we provide a Throttle Selector Guide on our web site ([www.InPowerLLC.com](http://www.InPowerLLC.com)). Simply select the chassis and model year, and it will display the minimum software revision. The DBT-LD throttle is reprogrammable, so that software may be updated as necessary.

### Key Features

- Supports Ford and Chevy light-duty vehicles .
- Low cost with fast and easy installation.
- Automatic charge protect and fixed speed modes.
- Data bus cable connects to OBD-II connector.
- No Ford SEIC wiring required.
- LED status and diagnostic indicators.
- Extra OBD-II connector in data bus cable.
- Customized functions available.

### System Diagram

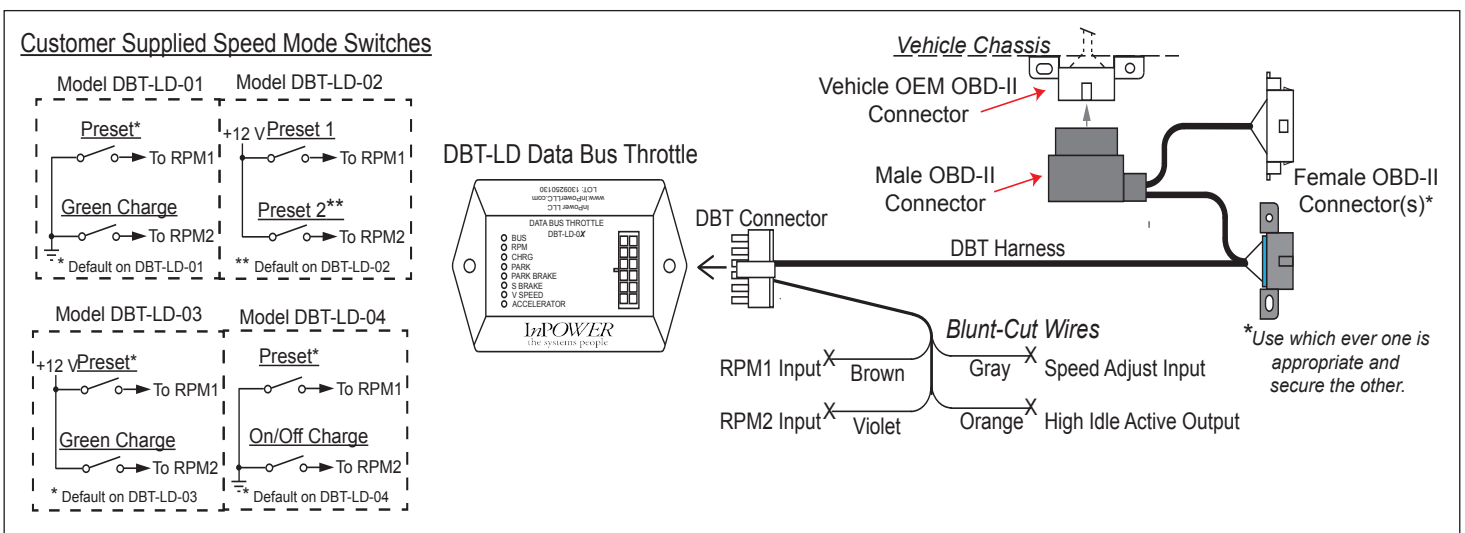

# DBT-LD

## Data Bus Throttle

# Light-Duty Vehicle Throttle

## Specifications

### Power Requirements & Notes

+12 volts:	Sourced from OBD-II connector
Ground:	Sourced from OBD-II connector
PTO Output:	+12 volts @ 3 amps. Set when module is activated.
RPM1:	+12 volts or ground as determined by software (see ordering guide)
RPM2:	+12 volts or ground as determined by software (see ordering guide)
Speed Adjust Input:	Adjusts preset RPM to desired value between 900 and 2000 RPM.
Dimensions:	3.17 L x 1.92 W x 0.79 H inches
<b>Charge Protect Modes:</b>	Activated when chassis battery voltage is low
Green Charge:	Gradually increases engine RPM to minimum required to charge battery, then lowers once charged.
On/Off:	Immediately increases engine RPM to 1500 to quickly charge chassis battery

### Chassis Ready Conditions:

1. Engine running at idle speed below 1,000 RPM.
2. No vehicle speed.
3. Automatic transmission in Park.
4. Service brake not depressed.
5. Accelerator pedal not depressed.
6. Parking brake set.
7. No Diagnostic Trouble Code (DTC).  
Check Engine light must be off.

### LED Status Indicators:

BUS	Module On & Data Bus Communications
RPM	In elevated fixed speed mode
CHRG	In Auto Charge Protect mode
PARK	Transmission in Park
PARK BRAKE	Park Brake set
S BRAKE	Service Brake set
V SPEED	Vehicle movement detected
ACCELERATOR	Accelerator depressed

## Ordering Guide

Model	RPM1	RPM2	Activation Polarity	RPM1 Factory Setting	RPM2 Factory Setting	Highest Priority
DBT-LD-01	Preset	Green Charge	Ground	1500	N/A	RPM1
DBT-LD-02	Override Preset	Standby Preset	+12 Volt	900	1500	RPM2
DBT-LD-03	Preset	Green Charge	+12 Volt	1500	N/A	RPM1
DBT-LD-04	Preset	On/Off Charge Protect	Ground	1500	N/A	RPM1

## Mechanical Drawing

