

# SERIES 28X HI-AMP HEAVY DUTY CIRCUITBREAKER

## AUTO, MANUAL & SWITCHABLE RESET CIRCUIT BREAKERS

### SPECIFICATIONS

#### Single Pole Thermal Type Breakers

**Applications:** Typically used in auxiliary and accessory circuits in truck, bus, RV and marine systems. Others include battery chargers and DC audio systems.

**Rating:** 25-200A; 48VDC max

**Interrupt Rating:** 3,000A @ 48VDC

**Operating Temperature Rating:** -40°C to 85°C

**Storage Temperature Rating:** -40°C to 125°C

**Materials:** Black thermoset plastic. Thermoplastic elastomer stud insulators are provided with F-style (surface-mount) bases.

**Marking:** Standard marking includes amp ratings and part numbers. Custom markings also available.

**Termination:** M6 threaded stainless steel studs.

**Torque Rating:** M6 50in-lb (5.6Nm) max

**Mounting Torque Rating:** Panel or surface-mount options; 50in-lb (5.6Nm) max.

**Ingress Protection Rating:** IP67.

**Features / Options:** The Series 285 has a unique yellow reset mechanism which provides visual indication of tripped condition. Series 285 also features a red push-to-trip option.

**Compliances:** SAE J1625; ABYC E-11; CE; SAE J1171 (Ignition Protected).



### DIMENSIONS (Dims. shown are for reference only. Consult factory for latest prints)

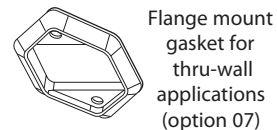
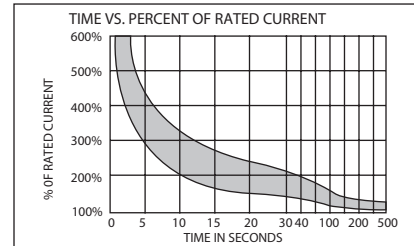
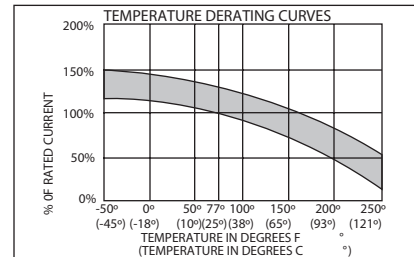
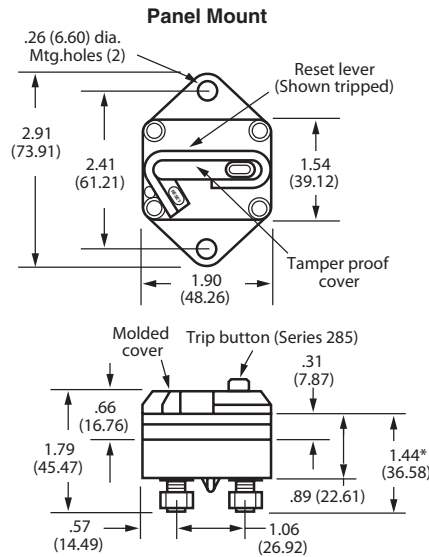
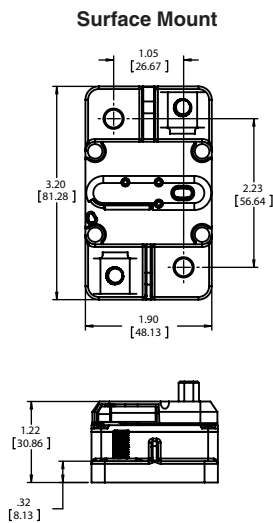

### PART NUMBERING SYSTEM

Series	Rating	Mounting	Hardware	Terminal	Marking
28	000	-	00	-	0
285 - Type III-PTT, 48V	025 - 25 amps 030 - 30 amps 035 - 35 amps 040 - 40 amps 050 - 50 amps 060 - 60 amps 070 - 70 amps 080 - 80 amps 090 - 90 amps 100 - 100 amps 110 - 110 amps 120 - 120 amps 135 - 135 amps 150 - 150 amps 200 - 200 amps	F - Surface Mount P - Panel Mount	00 - No hardware 12 - Stainless nuts and lockwashers installed	1 - M6	0 - Blank cover 1 - Standard Marking; Part Number, Amp Rating S - Standard Ignition Protected Marking (Consult factory for special markings.)

Uncontrolled Document  
Last Revision: 02.17.2022