

RENNSTEIG TOOLS, INC.

PRODUCT NAME

Rennsteig Crimping Die Set & Locator for HES 1.0 (Regular Wall) terminals

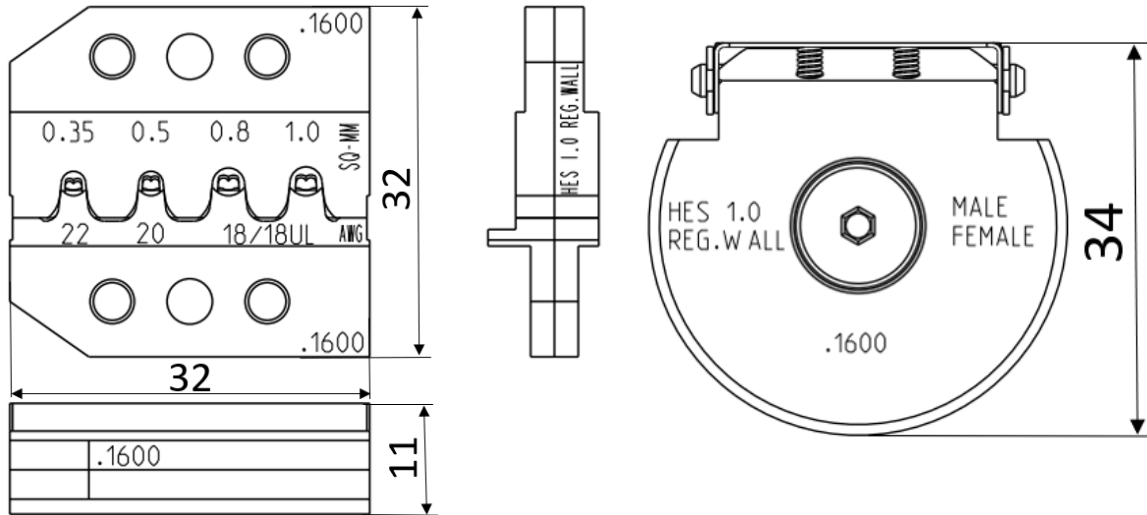

Measurements in Millimeter.

SPECIFICATION

P/N	Description	Application	Terminal P/N	Capacity	Applicable for
624 1600 3 0 RT	Die Set	HES 1.0 (Regular Wall)	13654423 13654421 13663727	AWG 22/20/18/18UL 0.35 / 0.5 / 0.8 / 1.0 mm ²	Rennsteig Crimp System Tools
624 1600 0 01 RT	Locator	HES 1.0 (Regular Wall)	13654423 13654421 13663727	AWG 22/20/18/18UL 0.35 / 0.5 / 0.8 / 1.0 mm ²	Rennsteig Crimp System Tools

CRIMP SPECIFICATION

Core Crimp

Terminal	Wire Size	Crimp height CCH (mm)	Crimp width CCW (mm)	Pull out force (N) DIN EN 60352-2
13654423	AWG 22 / 0.35 mm ²	0.85 ± 0.05	1.60 ± 0.1	40 (nominal)
13654421	AWG 22 / 0.35 mm ²	0.85 ± 0.05	1.60 ± 0.1	40 (nominal)
13654423	AWG 20 / 0.5 mm ²	1.05 ± 0.05	1.60 ± 0.1	60 (nominal)
13654421	AWG 20 / 0.5 mm ²	1.05 ± 0.05	1.60 ± 0.1	60 (nominal)
13663727	AWG 18 / 0.8 mm ²	1.15 ± 0.05	1.90 ± 0.1	90 (nominal)
13663727	AWG 18 / 1.0 mm ²	1.25 ± 0.05	2.00 ± 0.1	108 (nominal)

Insulation Crimp

Terminal	Wire Size	Insulation height ICH (mm)	Insulation width ICW (mm)
13654423	AWG 22 / 0.35 mm ²	2.30 ± 0.1	2.30 ± 0.1
13654421	AWG 22 / 0.35 mm ²	2.30 ± 0.1	2.30 ± 0.1
13654423	AWG 20 / 0.5 mm ²	2.30 ± 0.1	2.30 ± 0.1
13654421	AWG 20 / 0.5 mm ²	2.30 ± 0.1	2.30 ± 0.1
13663727	AWG 18 / 0.8 mm ²	2.60 ± 0.1	2.90 ± 0.1
13663727	AWG 18 / 1.0 mm ²	2.70 ± 0.1	3.00 ± 0.1

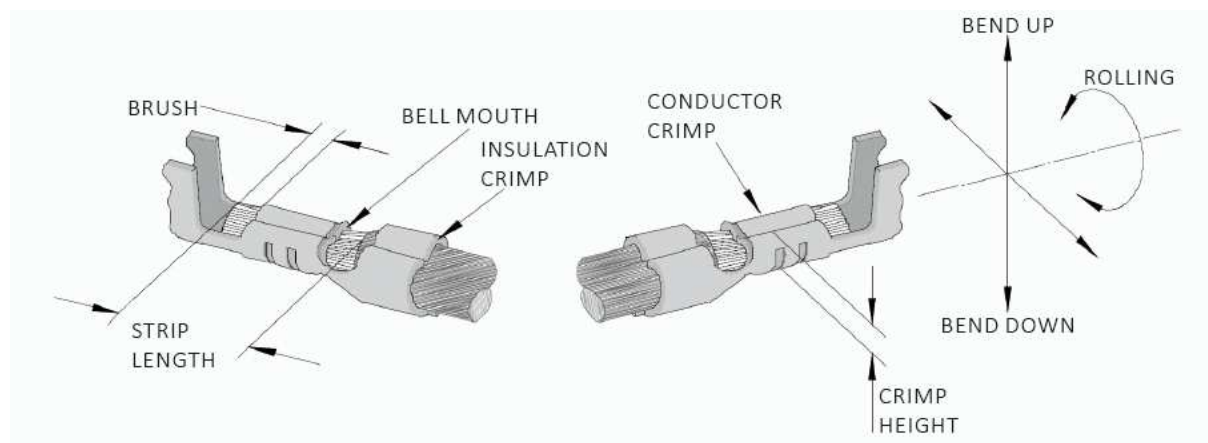

The above terminal drawing is a generic terminal representation. It is not an image of a terminal listed in the scope.