

SARGENT

6220 CT ADJUSTMENT PROCEDURE

INSULATED AND NON-INSULATED CRIMP TOOL
FOR 2-8 AWG WIRE

This tool is adjusted at the factory and no further adjustment should be required.

Should the tools, through extended use, require adjustment, wear in the parts may be compensated for as follows:

1. Close tool handles until pre-load is reached (this is the point at which jaws butt).
2. Measure the distance between the outside of the handles at the end of the handle grips. The distance should be 10 1/2" - 10 7/8" (wear will decrease this distance).
3. To increase the pre-load setting, loosen the bottom set screw slightly by turning counter clockwise. Then tighten the top set screw by turning clockwise until the preload distance is 10 1/2" - 10 7/8". Tighten the bottom set screw to clamp the setting.
4. Recheck the set distance after making three crimps.

In addition, always remember to:

1. Verify your tool's adjustment prior to crimping.
2. Never exceed the specified handle distance when adjusting your crimp tool. Premature wear will result.
3. Lubricate linkages on a regular basis to maximize tool life.

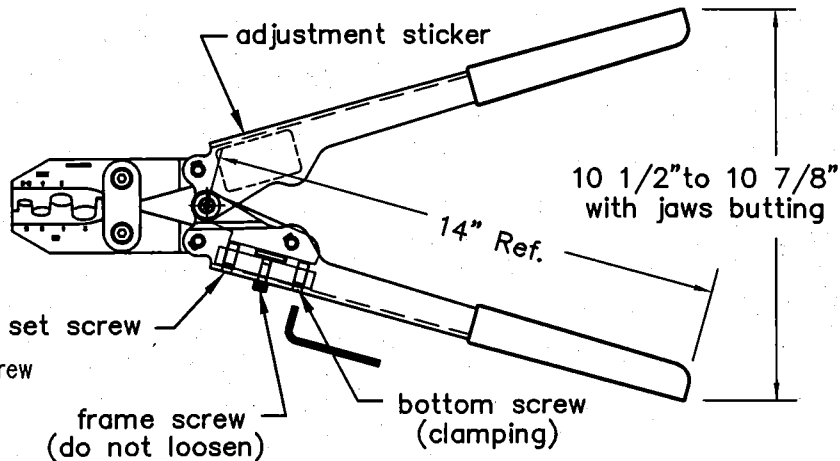

LIMITED WARRANTY

Rostra warrants that its product sold under the Sargent Quality Tool trade name are free from defects in workmanship and materials under normal use and service. This warranty does not cover defects or damage arising from improper installation, lack of or improper maintenance, improper storage, shipping and handling, or ordinary wear and tear, misuse, abuse, accident, unauthorized service, or use with unauthorized non-standard products or parts. The only liability of the company in tort or contract whether under this warranty or otherwise shall be limited to the repair or replacement of any product or component part which shall prove defective as covered by this warranty within one year after delivery to the original purchaser from the company. The manufacturer will not pay for the cost or repair performed other than in accordance with this warranty. The product or component part believed to be defective as covered by this warranty should be sent to the point of purchase for return to the manufacturer, and should include your name and address, an identification of the product or component part and a brief description of the defect. Shipping charges must be prepaid, for examination and, in the event such examination reveals a defect covered by this warranty, the product will be repaired or replaced. This warranty is in lieu of all other express warranties. To the extent permitted by law, all implied warranties are limited to the duration of this warranty. The manufacturer shall not be liable for the incidental or consequential damages. Some states do not allow limitation on how long an implied warranty lasts of the exclusion or limitation of incidental or consequential damages, so the above limitations or exclusions may not apply to you. This warranty gives you the specific legal rights, and you may also have other rights which vary state to state.

This warranty is null and void if the date coded adjustment sticker is removed

