

**NOTES:
MOUNTING TORQUE 30 INLBS**

REVISIONS				
REV.	DESCRIPTION	ECR	DATE	APPROVED
A	RELEASED	12483	3/20/23	RDM

D

C

B

A

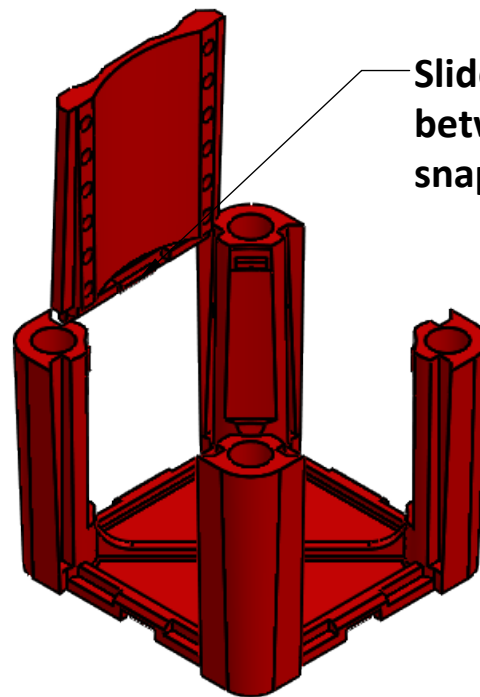
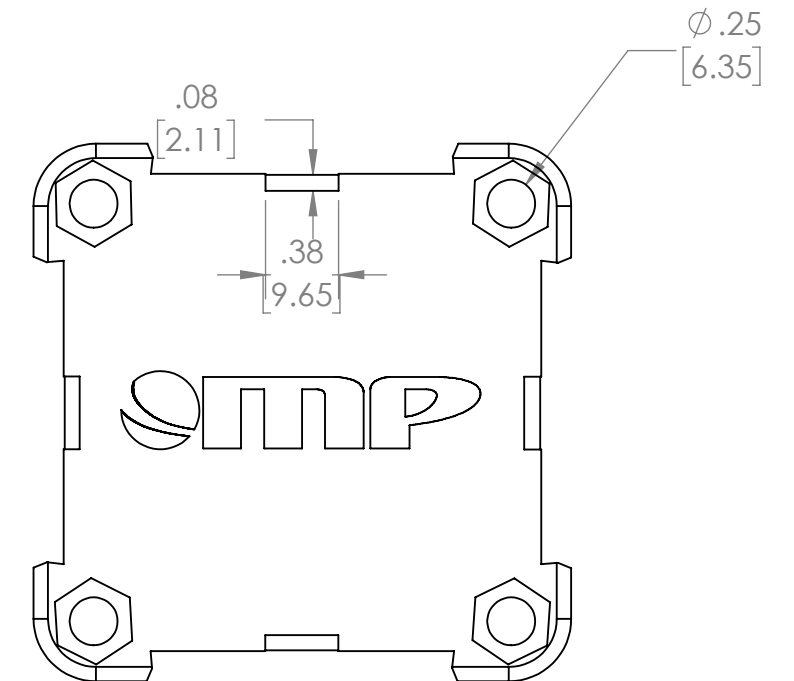
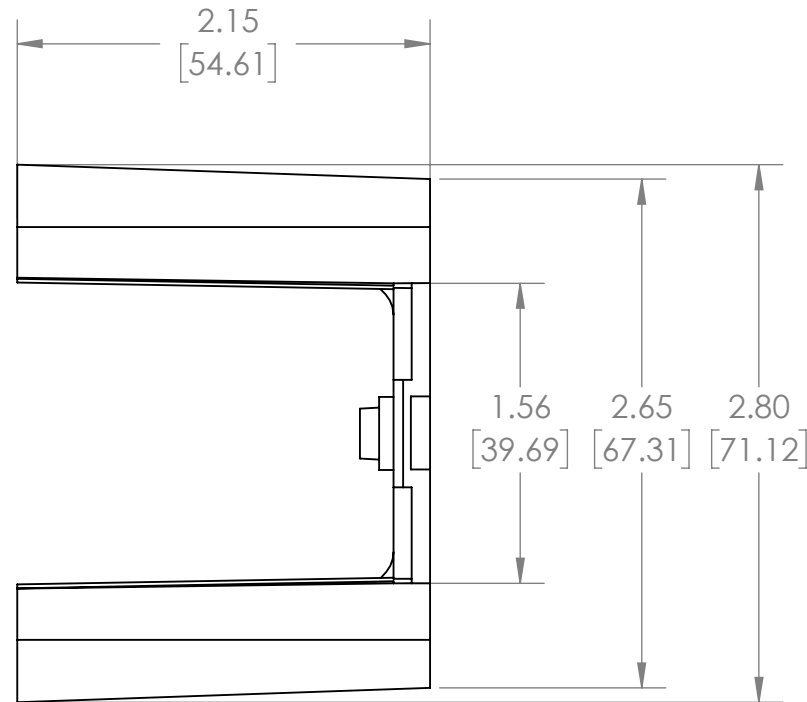
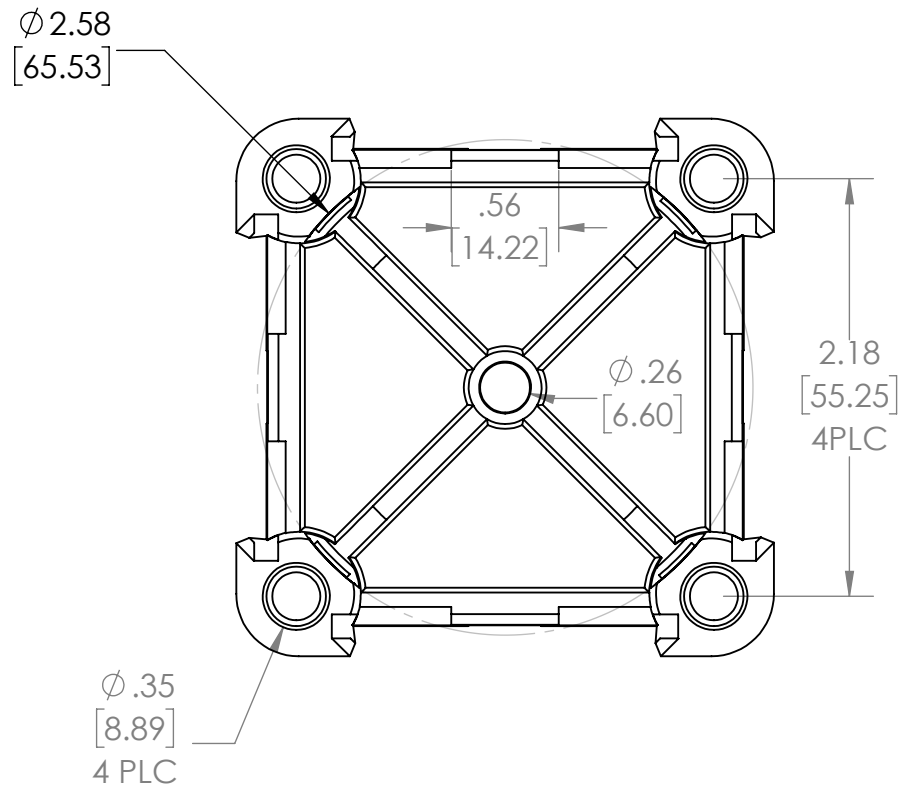

**Slide door (included) into slots
between legs until door locking tab
snaps into slot in bottom of stand-off.**

PROPRIETARY AND CONFIDENTIAL
THE INFORMATION CONTAINED IN THIS DRAWING IS THE SOLE PROPERTY OF MECHANICAL PRODUCTS, CO. ANY REPRODUCTION IN PART OR AS A WHOLE WITHOUT THE WRITTEN PERMISSION OF MECHANICAL PRODUCTS, CO. IS PROHIBITED.

UNLESS OTHERWISE SPECIFIED:		NAME	DATE	 Mechanical Products, Co. 1112 Garfield Street Lombard, IL 60148
DIMENSIONS ARE IN MM/INCHES TOLERANCES: METRIC: .X±.76 .XX±.13 ENGLISH: .XX±.03 .XXX±.005 ANGLES: ±1° FRACTIONAL: ±		DRAWN		
INTERPRET GEOMETRIC TOLERANCING PER:		CHECKED		TITLE: 67 SERIES STAND-OFF
MATERIAL		ENG APPR.		SIZE B DWG. NO. 670-807 REV A
FINISH		MFG APPR.		SCALE: 1:1 WEIGHT: SHEET 1 OF 1
NEXT ASSY	USED ON	Q.A.		
APPLICATION		COMMENTS:		
DO NOT SCALE DRAWING				

8

7

6

5

4

3

2

1

8

7

6

5

4

3

2

1