

MOUNTING RIVETS FOR - FTH-14R		
USE RIVET NO.	HOLE DIA.	FOR PANEL THICKNESS RANGE
SR-5055	.201 (5.1)	.020-.048 (0.5-1.2)
SR-5065		.048-.087 (1.2-2.2)
SR-5075		.087-.127 (2.2-3.2)
SR-5085		.127-.166 (3.2-4.2)
SR-5095		.166-.205 (4.2-5.2)
SR-5105		.205-.245 (5.2-6.2)

PART NO.	"A" DIA.	DIM. "B" C'BORE DIA.
FTH-14R-01	.21 (5.2)	.38 (9.5)
FTH-14S-01	.26 (6.6)	.49 (12.5)

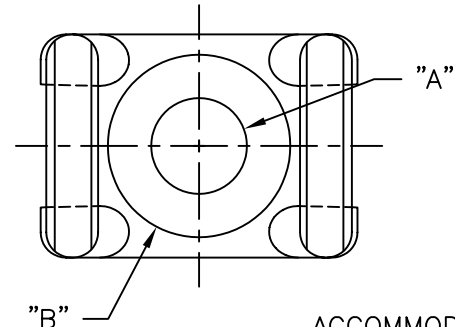

ACCOMMODATES WIT-18 THRU WIT-120, AND QTE-18 THRU QTE-120 TIES

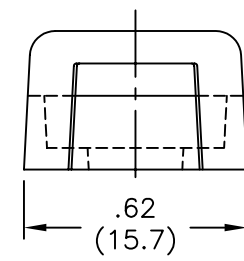
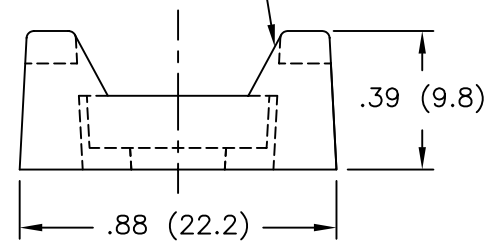

NOTES:

1. MATERIAL: NYLON 6/6 (RMS-01), COLOR NATURAL.
2. FLAME RETARDANT NYLON (RMS-19). COLOR NATURAL. AVAILABLE BY SPECIAL ORDER ONLY; TO ORDER USE P/N FTH-14R-19 OR FTH-14S-19.
3. UV STABILIZED NYLON 6/6 (RMS-46), COLOR BLACK. AVAILABLE BY SPECIAL ORDER ONLY; TO ORDER USE P/N FTH-14R-UVB OR FTH-14S-UVB.
4. MOUNTING SCREW FOR FTH-14R: NO. 10 (M5) FLAT, ROUND, OR PAN HEAD
MOUNTING SCREW FOR FTH-14S: NO. 1/4" (M6) ROUND OR PAN HEAD.

TITLE: FLAT TIE HOLDER		DWG IN IN (MM) FINAL			
TOLERANCES UNLESS NOTED .XX=±.010 .XXX=±.005 FRAC=±1/64 ANG=±1'	FILE # FTH-14X	DWN: E.P.	APP:	PART #	
	MAT'L: SEE NOTES	DT: 12-30-98	DT:	SEE TABLE	
	RE: RICHCO, INC.	RICHCO INC. PO BOX 804238, CHICAGO, 60680 (773) 539-4060		PRINT TYPE CA	

REV	DESCRIPTION	ENGR DATE
D	SEE ECN #1124 FOR CHANGES	SK 01.24.06
C	UPDATED PRINT AND CHANGED FILE NO.	SM 05.30.02
B	MAT'L RMS-19 ADDED, CABLE TIE NOTE UPDATED	JL 01.05.00
A	CORRECTED TABLE	AM 5/6/99